

PARTS LIST						
ITEM	QTY	PART NO.	PART DESCRIPTION	LENGTH	UNIT WT.	NET WT.
1	2	X-116165	3" V-CLAMP	5 1/16 in	1.03	2.06
2	1	X-119653	3" TO 3" 90° V-CLAMP BRACKET WITH 2" STANDOFF		1.97	1.97
3	4	G1204	1/2" x 4" HDG HEX BOLT GR5 FULL THREAD	4 in	0.27	1.08
4	8	G12FW	1/2" HDG USS FLATWASHER	3/32 in	0.03	0.27
5	4	G12LW	1/2" HDG LOCKWASHER	1/8 in	0.01	0.06
6	4	G12NUT	1/2" HDG HEAVY 2H HEX NUT		0.07	0.29
					TOTAL WT. #	5.73

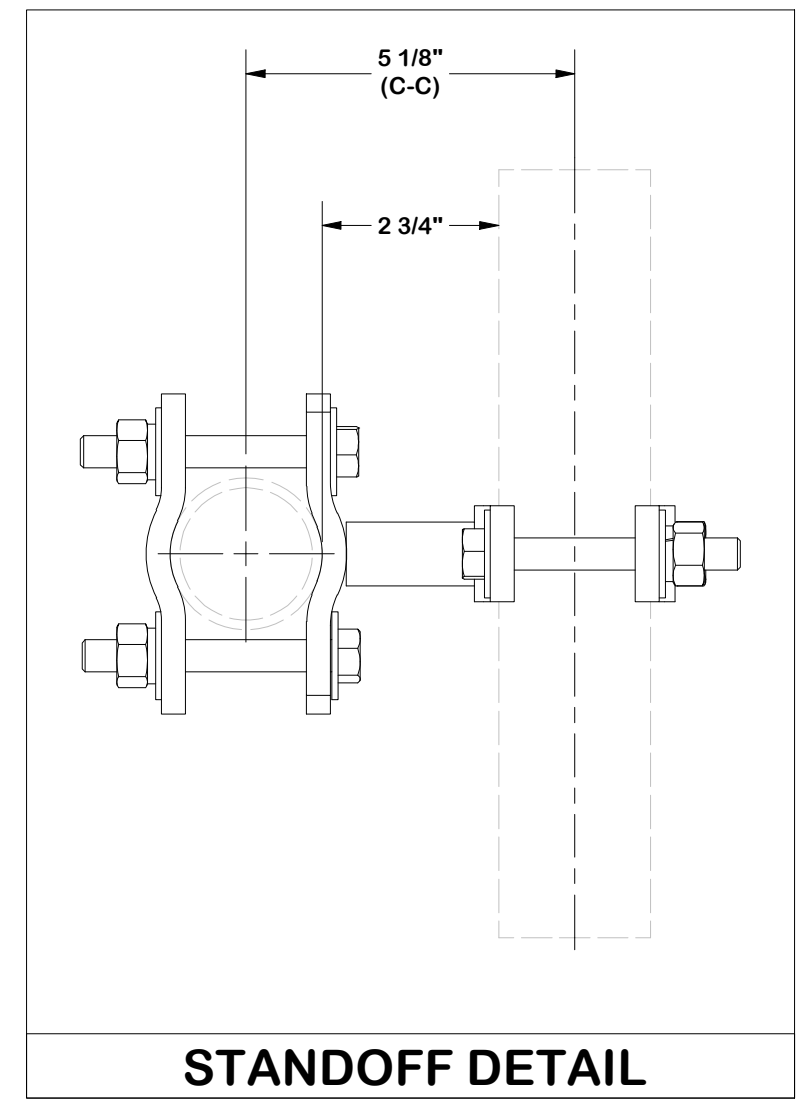
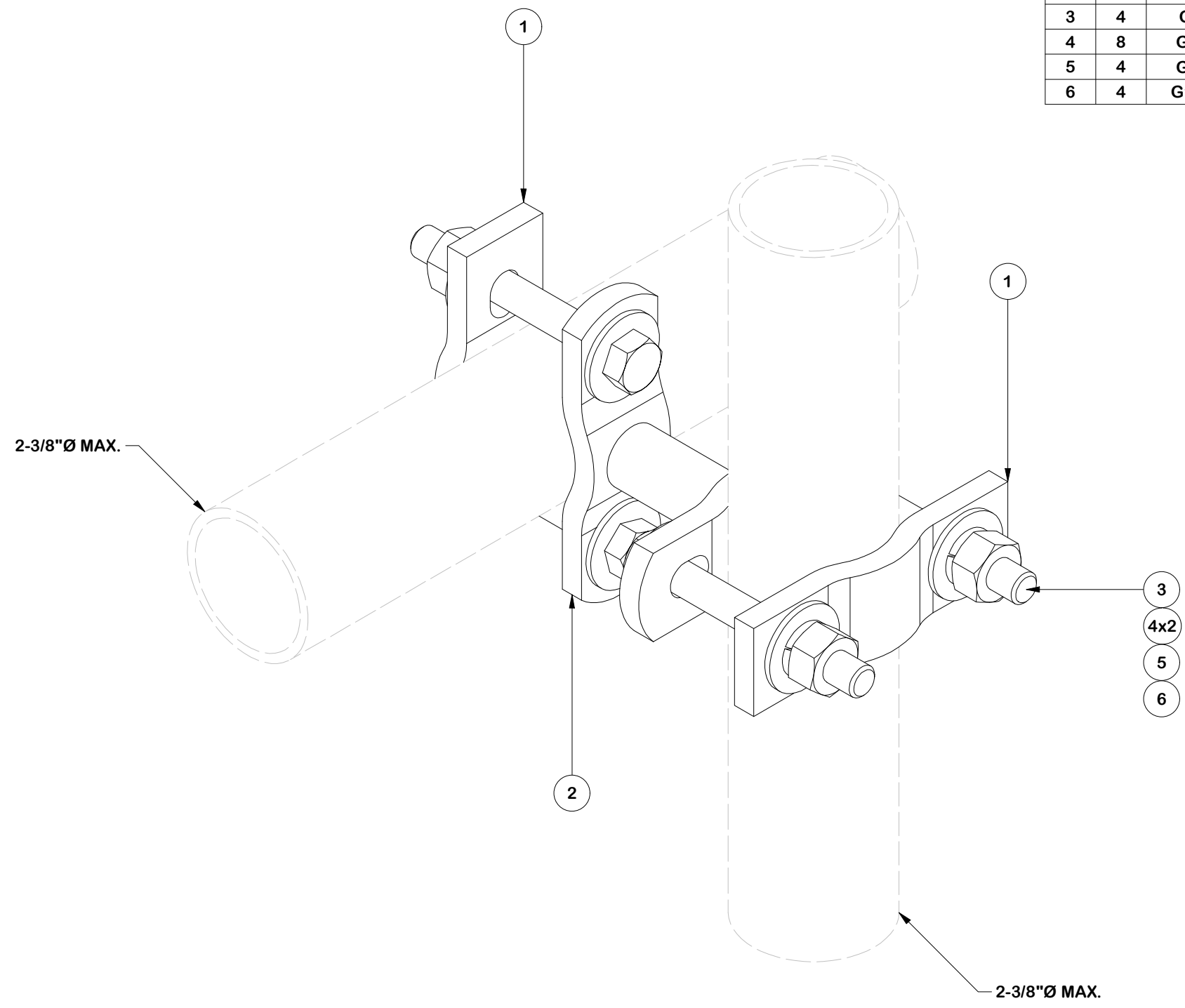

FINISH:
HOT DIP GALVANIZED.

TOLERANCE NOTES
 TOLERANCES ON DIMENSIONS, UNLESS OTHERWISE NOTED ARE:
 SAWED, SHEARED AND GAS CUT EDGES ($\pm 0.030"$)
 DRILLED AND GAS CUT HOLES ($\pm 0.030"$) - NO CONING OF HOLES
 LASER CUT EDGES AND HOLES ($\pm 0.010"$) - NO CONING OF HOLES
 BENDS AND ANGLES ARE $\pm 1/2$ DEGREE
 ALL OTHER MACHINING ($\pm 0.030"$)
 ALL OTHER ASSEMBLY ($\pm 0.060"$)

PROPRIETARY NOTE:
 THE DATA AND TECHNIQUES CONTAINED IN THIS DRAWING ARE PROPRIETARY INFORMATION OF VALMONT INDUSTRIES AND CONSIDERED A TRADE SECRET. ANY USE OR DISCLOSURE WITHOUT THE CONSENT OF VALMONT INDUSTRIES IS STRICTLY PROHIBITED.

DESCRIPTION
 2-3/8" x 2-3/8" V-CLAMP
 CROSSOVER KIT
 W/ 2-3/4" STANDOFF

CPD NO.	DRAWN BY	ENG. APPROVAL
	CMFL 1/24/2023	
CLASS	SUB	DRAWING USAGE
87	02	CUSTOMER
		CHECKED BY



A valmont COMPANY

Locations:
 New York, NY
 Atlanta, GA
 Los Angeles, CA
 Plymouth, IN
 Salem, OR
 Dallas, TX
 Tampa, FL

Engineering Support Team:
 1-888-753-7446

PART NO.	VCX1-2K
DWG. NO.	VCX1-2K